



High Technology in Refrigeration Devices

PRODUCT DOCUMENTATION

TREF

Air Conditionig units for Close Control Application

"R" Advanced Direct Driven Plug fans

TA..R	➔ Direct Expansion Up/Down Flow
TW..R	➔ Direct Expansion Water condensed Up/Down Flow
TF..R	➔ Direct Expansion Indirect Free Cooling Up/Down Flow
TQ..R	➔ Dual Cooling Water condensed Up/Down Flow
TD..R	➔ Dual Cooling Air condensed Up/Down Flow
TC..R	➔ Chilled Water Up/Down Flow
T..XR	➔ Displacement Version





High Technology in Refrigeration Devices



Index

General Description	<input type="checkbox"/>
Configuration Digit	<input type="checkbox"/>
Main characteristics & features	<input type="checkbox"/>
Application field	<input type="checkbox"/>
Technical section	<input type="checkbox"/>
Overview of the range	<input type="checkbox"/>
DX Air Cooled Units Technical Data	<input type="checkbox"/>
DX Water Cooled Units Technical Data	<input type="checkbox"/>
CW Units Technical Data	<input type="checkbox"/>
Remote Condensers	<input type="checkbox"/>
Remote Dry Coolers	<input type="checkbox"/>
Correction factors	<input type="checkbox"/>
Drawings	<input type="checkbox"/>
Legend	<input type="checkbox"/>

General Description of TREF units

Example of a DX Air Cooled Unit Type TADR:

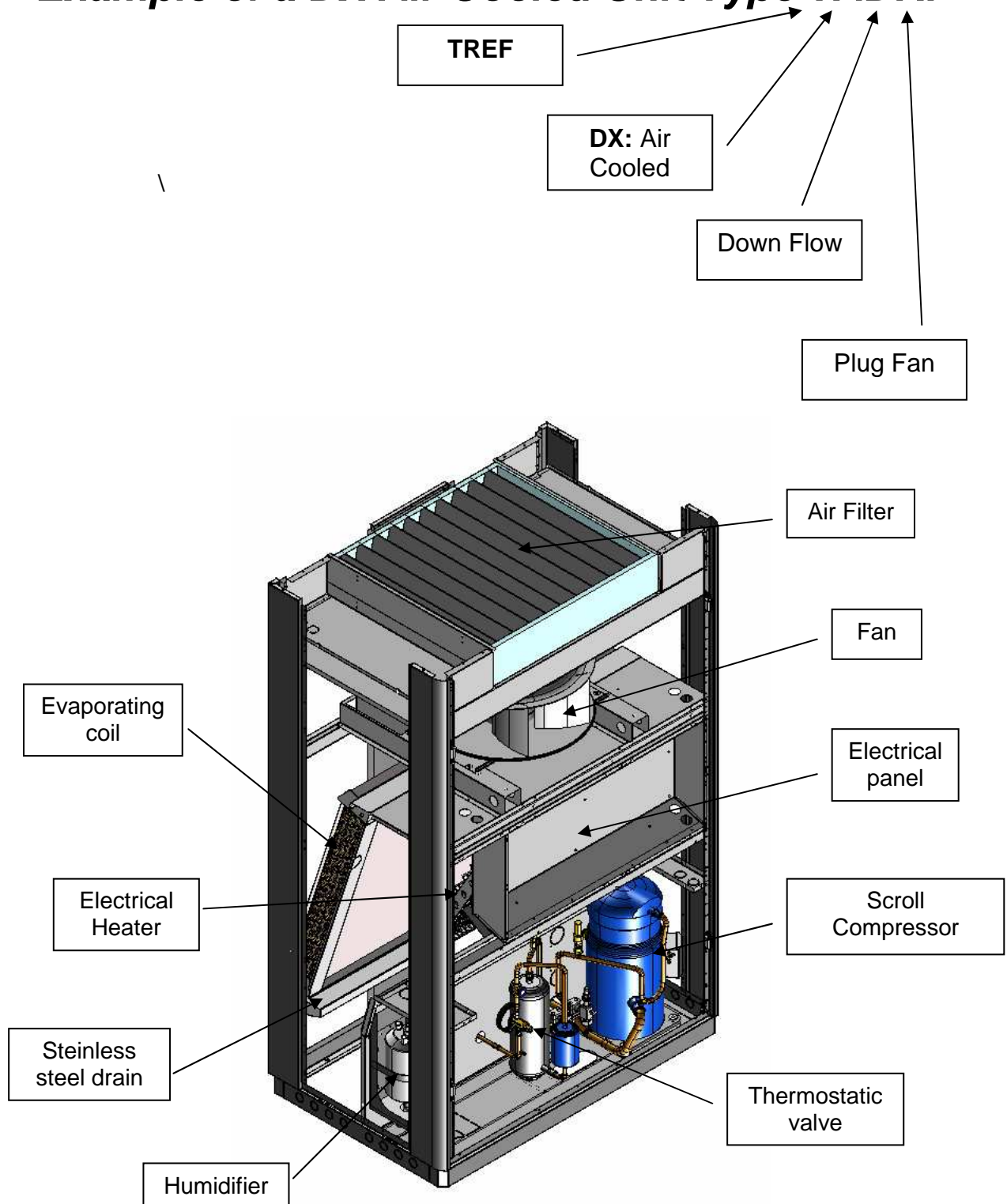

Example of a CW Unit Type TCDR:

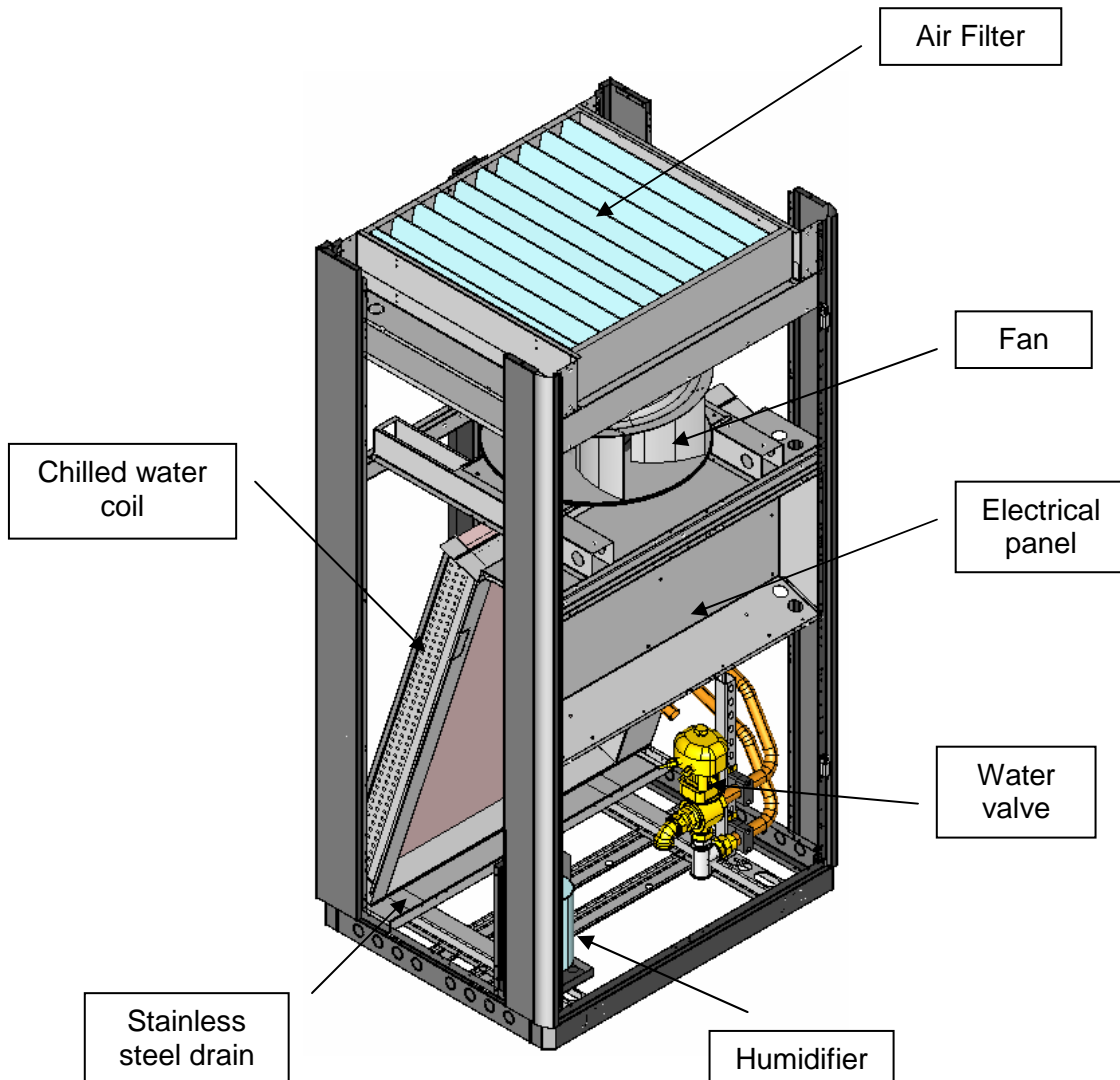
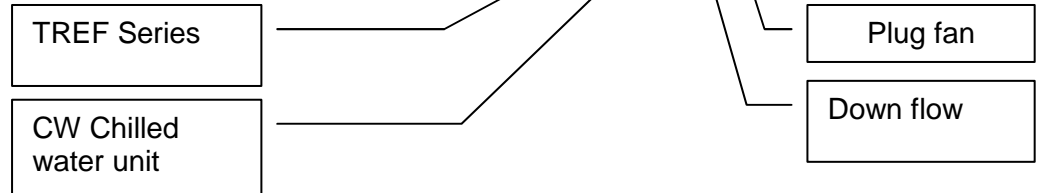



DIGIT

DIGIT Configuration

The TREF product range consists of 20 models with a cooling capacity from 21,2 to 41,2 kW in single circuit version and from 26,9 to 76,2 kW in double circuit version. The units are available in different air flow configurations and in DX or CW version according to the configuration DIGIT shown below. For the correct choice between possible configurations the electronic configuration software shall be applied.

DX Units : example...

T A D R **0 4 5 2** **1 2 3 4 5 6 7 8 9 10 11**

T : TREF series

DX Direct expansion units
A: remote air condensed units
W: water condensed units
F: free cooling ("R" radial fan version only)
D: dual cooling (Water coil + DX coil remote condensed)
Q: dual cooling (Water coil + DX coil water condensed)

Air Flow
D: Downflow
U: Upflow
X: Displacement

Fans
R: Radial fan with backward curved blades

Cooling capacity
KW / 10

N° of refrigerating circuits
n°

	Configuration	
1	Power supply 400V / 3 ph + N / 50Hz	3
2	Control Basic – Carel µAC Advanced (with local interface) – Carel pCO1	0 B
3	Refrigerant R407C R407C with electronic expansion valve R22 (Special) R22 with electronic expansion valve (Special)	0 1 2 3
4	Fan Brushless <i>EC Technology</i>	E
5	Humidifier No Dehumidification Dehumidification + steam humidifier	0 4 5
6	Electrical Heaters No Yes	0 F
7	Re-Heating system No Hot gas coil modulating On/Off (Special) Hot gas coil modulating (only advanced control) (Special) Hot water coil with 0-10V signal activated valve (Special)	0 4 5 7
8	Air filtration G3 (standard) G4 G3 + clogged filter sensor G4 + clogged filter sensor F5 F5 + clogged filter sensor	0 H I L P Q
9	Condensing control 230V/1ph/50Hz None Mod. fan speed control with MCB (advanced) for single circuit condensers Mod. fan speed control with MCB for double circuit condensers Flooding technology refrigerant side with back pressure valve (in „F“ version = standard) 2-way water pressostatic valve for watercooled „Z“ & „Q“ version	0 5 6 7 9
10	Packaging Standard Wooden crate with cardboard Seaworthy	0 M N
11	Special Standard Special	0 S



DIGIT

DIGIT Configuration

CW Units : example...

T C D R 1 0 0 0 1 2 3 4 5 6 7 8 9 10 11

TREF series

CW chilled water units
C: basic configuration
S: slave unit without control

Air Flow
D: Downflow
U: Upflow
X: Displacement

Fans
R: Radial fan with backward curved blades

Cooling capacity
KW / 10

N° of refrigerating circuits
n°

	Configuration	
1	Power supply	
	400V / 3 ph + N / 50Hz	3
2	Control	
	Basic (with local interface) – Carel µAC	0
	Advanced (with local interface) – Carel pCO1	B
	Slave unit without microprocessor (Special)	C
3	Valve	
	3-way-valve with 3-point motor	0
	3-way-valve with 0-10V signal activated motor	3
4	Fan	
	Plug fan with asynchronous three-phase motors (Special)	0
	Plug fan with Brushless motor	E
5	Humidifier	
	No	0
	Dehumidification	4
	Dehumidification + Steam hum. with humidity sensor	5
6	Electrical Heaters	
	No	0
	Yes – 3 steps	F
7	Re-Heating system	
	No	0
	Hot water coil with 3 point activated valve (Special)	5
	Hot water coil with 0-10V signal activated valve (Special)	6
8	Air filtration	
	G3 (standard)	0
	G4	H
	G3 + clogged filter sensor	I
	G4 + clogged filter sensor	L
	F5	P
	F5 + clogged filter sensor	Q
9	Condensing control	
	No	0
10	Packaging	
	Standard	0
	Wooden crate with cardboard	M
	Seaworthy	N
11	Special	
	Standard	0
	Special	S



Main characteristics

TREF CCAC Units

TREF CCAC self-contained units are specially designed for installation in technological environments with very high thermal loads such as computer rooms, laboratories, generally where high precision in climate control and a 24h/day operation is required. TREF units represent the state of the art between technology and design as known from all HiRef S.p.A. products. Thanks to their characteristics, TREF can be installed also in offices where people are working. The depth of 795 mm allows to pass through standard doors and furthermore the innovative design and the high tech selected colours make TREF units complementary to the last generation of IT devices. All panels are made in galvanized steel with powder coated finish for an outstanding quality level. The internal design of the units are made to achieve best efficiency and reliability and at the same time to do not lose accessibility: **all** components, including e-heaters, fans, compressors, valve, steam pipes, etc. can be maintained from the front. Additionally the frontdoor(s) are dismantable in just a few seconds thanks to an innovative hinge: an important advantage when units are installed in narrow corridors. The exclusive use of primary brand components and a fully integrated development process (CAD+CAM, CAE) stands for highest possible quality level regarding efficiency, reliability, maintenance time, pre- and after sales support. The DX units are available with a single circuit or with double circuits, to obtain a greater application flexibility, more efficiency @ partial load and -of course- more reliability. DX versions available also in "W" water cooled for dry cooler applications (40/45° 30% e.g.) or for city water, "F" indirect Free-Cooling, "Q" dual cooling (Dx coil + CW coil) water cooled, "D" dual cooling (Dx coil + CW coil) with remote condenser and "X" displacement version with an average discharge air speed < 1,1 m/s.

Frame

TREF units are designed with a self-supporting frame and all components are produced in-house, using sophisticated computer driven machines and special tools. All sheet metals are galvanized and all external panels are powder coated in RAL 7016 colour giving the units an image and the quality like the last generation of IT devices. The units are completely closed and only a frontal access is necessary. Nevertheless it is also possible to have side access for any additional need. The shape of the units is characterized by bended edges with variable radius:

this feature is obtained by using special manufacturing tools and gives both - a good aesthetic - and an advantage to prevent injuries. The compressor compartment is separated from the air flow and a special internal design allows to simply dismount the upper part of it guaranteeing an insuperable accessibility to all refrigerating components.

All fixing elements are made in stainless steel or in non corroding materials. The drain pan is made of stainless steel in order to ensure long life-time operation without damages.

All panels are thermally insulated with a polyurethane foam class 1 according UL 94 norms: this material, thanks to the open cells, gives excellent performance in sound absorption. Optional sandwich panels are available: in this case mineral fibre layers are closed between the panel and a second sheet of metal, giving a maximum in terms of internal cleaning and resistance against fire. The sound insulation of sandwich panels is better than the standard solution, but the internal reflected sound power increases the Lw on delivery side (+2dB).

Refrigerating circuit

The entire refrigerating circuit is assembled in HiRef's proper workshop, including all pipe work, using only primary brand for components. The workers involved in the welding and pipe work process are qualified by a third part according CEE 97/23 PED directive: necessary to underline that this qualification for workers was not request, but it was HiRef's decision taking care about the quality and -in general- for the customer 's satisfaction. The DX units are present in single or double circuit execution and are precharged with dry nitrogen for "A", "D" or with R407C refrigerant for "W", "F", "Q", "D" versions. Refrigerant different from R407C, like R22, R134a, R410A are available on request and previous check for local rules.

- ❑ Compressors: on TREF units only primary brand scroll compressors are installed. Scroll compressor represent for CCAC units the best solution in terms of efficiency and reliability. The internal compression ratio is very close to the typical operating condition of CCAC giving the maximum in terms of COP and the perfect balanced pressures at start up gives big advantages to the e_motor in terms of reliability, mainly in this field where frequent start ups can happen.



High Technology in Refrigeration Devices

- **Plate heat exchangers:** only AISI 304 BPHE with low carbon steel connections are used. The special design of the plates gives both an advantage to increase the turbulences -reducing the fouling and increasing the efficiency- and a reduction of the overall dimensions: this feature allows to install the BPHE behind the compressor compartment, giving more space for piping and other components.

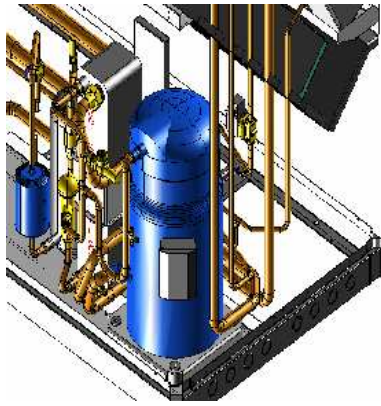

- **Finned coil heat exchanger:** the know-how of the development and production of this "FCHE" is within the Galletti Group. All coils are made by using a 25 x 21,65 mm geometry in combination with 9,52 mm copper pipes and aluminium fins of 0,10 mm thickness. The expanding process to ensure perfect contact between pipes and fins is one of the most critical points and it is 100% monitored in the whole production process. Design criteria in our R&D department and our laboratories are summarized in 4 main characteristics:

- Reduction of pressure drop by using a large front surface
- Hydrophilic treatment of the fins in order to allow a film condensation in dehumidification operation (typical angle water/aluminium <10°)
- Reduction of the vertical height to avoid big thickness in water film and - in consequence - the possibility to operate with high air volume and high r.h. without dragging out of water (especially in down flow units).
- Special corrugated fins increase the heat transfer coefficient air side in order to improve the SHR.

In chilled water units special attention was paid to checking the behaviour of the Reynolds figure inside the pipes during the modulation of the three way valve: transition between laminar and turbulent flow may cause a big step in heat exchanging efficiency loosing accuracy in T control.

Looking into advantages of spare parts: one same coil is used for both up and down flow units.

- **Remote condensers:** coils are made using the 25 x 21,65 mm geometry in combination with 9,52 mm copper grooved pipes and aluminium louvered fins with 0,10 mm thickness: the combination of this

technologies allows the maximum reduction in internal volume and - in consequence - a reduction of the refrigerant charge. The adopted fans are only with external rotor motor, in 4 or 6 poles execution, depending on the selected sound power level: in the catalogue two selections are already available, but special requests can be followed by the HiRef R&D department. The panels are made in galvanized precoated steel. Special feet for horizontal installation with vertical airflow are available for the whole range (optional).

Looking to the destination of such units, four different type of condensing controls are optional available:

- None
 - Modulating fan speed control in std alone version installed on the condenser
 - Modulating fan speed installed in the CCAC => down to -15°C
 - Flooding technology in addition to the fan speed control for temperatures below -15° and down to -30°C. This last option will be supplied as a kit including liquid receiver, back pressure valve, safety valve, protection cabinet and has to be installed on site just close to the condensing unit.
- **Refrigerating components:**
 - Filter with molecular sieve and activated alumina.
 - Sight glass with humidity indication.
 - Thermostatic valve with MOP function and external equalisation.
 - Electronic expansion valve for insuperable performances in middle and winter season: the pay back of the solution in north European countries is less than 1 Year.
 - Liquid receiver according CEE 97/23 PED directive
 - HP pressostat with manual reset according cat. IV CEE 97/23 PED.
 - LP pressostat with automatic reset and delayed time during start up.
 - Schrader valves for maintenance and or controls.
 - During the dehumidification phase all DX units (optional) operate with a reduced heat exchanger surface in order to decrease the evaporating T and as a consequence to increase the latent percentage.



High Technology in Refrigeration Devices

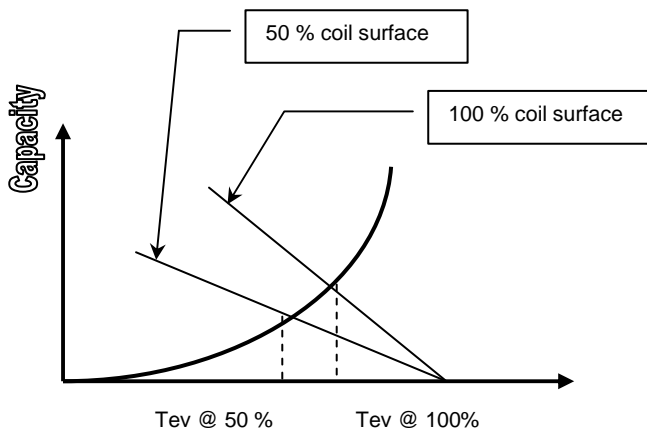

- Activating the different steps in e_heating (option)
- Alarm management
 - High / low ambient T
 - High / low Pressure refrigerant side
 - Air Flow
 - Dirty filters
 - E-heating
 - Humidifier general alarm
- Management of maximum compressor startups.
- Serial communications (optional) RS232 o RS485

Remote control and connection to BMS are possible as all mP are able to be connected in serial communication (the HSD [HiRef Software Development Team] is ready to support customers in system integration).

Interconnectivity is every day more a must :

- Serial ports
 - RS232
 - RS485
- Modem GSM: check with your local provider for the right contract for the SIM card. After activation, TREF units are ready for a stand alone bidirectional communication (only with Advanced pCO control)
- Protocols
 - Carel [Built In]
 - Modbus® [Built In with Advanced mP]
 - Modbus® [External gateway with basic mP]
 - LonWorks® [option to be selected at unit's ordering]
 - BACnet™ [External gateway]
 - TCP-IP[External gateway]
 - TREND® [option to be selected at unit's ordering]

Electrical panel & components

- Electrical panel: fully contained in the unit it is designed according CEE directives 72/23, 89/336 and related norms. The possibility to have access to the e-panel opening the doors is needed: with open doors the protection still remains IP 30 thanks to a protecting transparent plastic panel in front of the components. All remote signals are @ very low voltage 24 Vac by means of a safety transformer. All e-panels have an air circulation system in order to keep the inside T under control when the unit is in operation. All connected loads are protected with automatic switches in addition to those already present inside the compressors and fans. All three phase units are standard equipped with a phase sequence relay: this device checks the sequence of the phases avoiding the start of the compressors in the wrong direction.
- Microprocessor: two different type are available:
 - Basic – Carel μ Ac
 - Advanced – Carel serie pCO1 in combination with the semigraphic pGD Display. For this control the HiRef Software Development Team is prepared to customize software according to customer specifications.

The main functions are summarised in:

- Input of main parameters by means of the keyboard.
- Displaying of operating conditions, alarms, devices
- Switching on/off or modulating (3 way valve, humidifier) resources to keep constant the environment parameters.
- Modulating the three way valve for hot water reheating (option)
- Activating-deactivating the solenoid valve for hot gas reheating in DX version only (option)
- Modulating the humidifier capacity

Aeraulic section

Fans for all versions are radial type direct driven in combination with 4 poles motors with three phase power supply. Fans are statically and dynamically balanced ensuring a drastic reduction in noise and vibrations. All models can be equipped with EC fans with brushless motors (optional): this technology allows to reduce energy consumption mainly at partial load and allows to maintain the air flow independently from external conditions. The air circuit is completed with an air flow switch that checks fan's faulty situation.

Hydraulic Circuit

CW units are fully assembled and pressure tested in the factory final test. The 3-way-valves are selected by comparing the Kvs to the coil pressure drop in order to give to the valve the adequate authority for a good water flow control. The valve body is made in brass OT 58 and the shutter is plated in RILSAN for the maximum tightness: the Unit system is PN16. The external connection are standard supplied with 3 parts quick connections to reduce on site working time.



High Technology in Refrigeration Devices

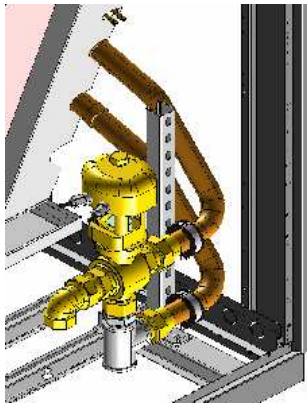

Air Filter

The filters are positioned on the Top (Down Flow) or just in front of the coil (Up flow) and are made in synthetic material with metallic frame. Filtration efficiency is G4 according CEN EN 779. To exchange the filter, simply open the door(s) and remove it. As an option in the same dimension it is possible to install up to F5 filters, without any modification on the ventilation. For a higher filtration efficiency up to F9, an external plenum is needed. In this case a G4 filter will be part of the option as a prefilter. With up flow units the High filtration plenum is positioned on the discharge side.

Humidifier

The steam humidifier is fully controlled by the mP as well as all operating parameters like water level, water conductivity, current through electrodes. Fixing the tension, the current and obviously the steam capacity depend from the water conductivity and the water level: the algorithm mixing all parameters ensures the right steam production avoiding at the same time foam grooving into the cylinder. After a certain period - depending on the water characteristics- the cylinder has to be replaced by a new one: an European average is 3 cylinders / Year for full time operation.

Humidity control

TREF units can be supplied with Humidity sensor (option). For an independent control between T and r.h. it is necessary to adopt one of the reheating possibilities (options)

- Electrical reheating.
- Hot Water with 3 way modulating valve.
- Hot gas reheating: this solution is only for DX version and - looking to energy consumption – it is made with zero extra energy: this option is available in On/Off version or in modulating version for more precision in parameters control. The reheating coil design criteria allows to have bigger heating than sensible cooling capacity allowing to dehumidify even when there are no thermal loads inside.

Water condensed versions

DX Units water condensed "W" "Q" "F" "D" are equipped with an AISI 304 brazed plate condenser. Units are supplied fully tested and charged with POE oil and refrigerant. During the final factory test, all operating parameters are measured and memorized, they are available on request.

According to water T (city water) it is possible / needed to add a 2 way condensing control valve. In case that it is not possible to reduce the water flow, flooding technology is the alternative: in this case only refrigerant side actions occur and the water flow remains constant.

The condenser is located inside the compressor compartment and is fully reachable from the front of the unit

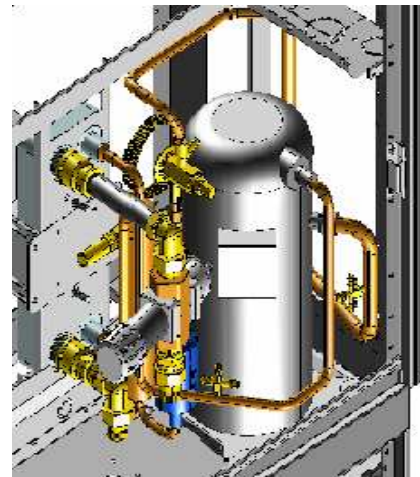

Fresh air kit

Fresh air kit consists of a flexible pipe and a cartridge G3 filter and under normal conditions ensures roughly 150 m3/h independently from the unit's model. In down flow units the filter is located in the fans section and before removing the filter it is necessary to stop the unit and to remove the sheet metal of the fan's compartment. In up flow units an additional booster fan is provided to ensure roughly 80 m3/h for all models and the relative filter is located just close to the main filter.

Plenum Kit

Suction/delivery plenum with 300mm and 500mm height are available. In case of down flow units such plenums can be equipped with silencer cartridges, damper section for Direct Free-Cooling and high efficiency filters. In case of up flow units the delivery plenum can be fitted with aluminium grills for frontal air discharge.



High Technology in Refrigeration Devices

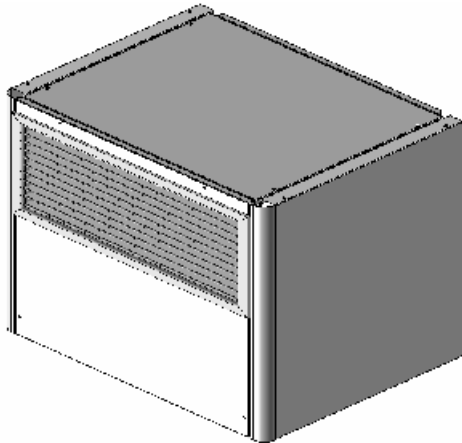

Base Frames/Floorstands

Made in galvanized steel, are available in three different heights 300 - 500 - 800 mm, with excursion +/- 25mm.

Electrical Heaters

Made in aluminium with a large surface for keeping the lowest possible surface temperature (less than 130 °C), and is working in a 3 steps operation mode. Each element is provided with an independent safety thermostat. Despite the very small depth of the unit, the elements are mounted in a special rail in order to extract them from the front of the units. This is possible with all TREF models, UP and Down flow.

Before any maintenance on electrical heaters, disconnect the units from power supply and wait min. 30 minutes, allowing the temperature to decrease.

Application Field

TREF units are designed for indoor installation in technological environments but have been tested also under extreme conditions, typical for far East markets: the indoor temperature limits are between 18°C and 32°C with a r.h up to 75% on the whole range. Practically indoor conditions don't play any role for a reliable operation.

The application field for DX units -water or air condensed- is shown in the relative diagrams:

▪ Water condensed:

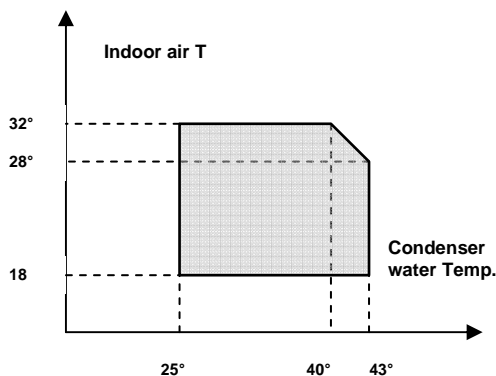

For water T under 25°C a condensing control valve is needed (option):

- ❑ Using a 2 way modulating valve water side. The valve is installed in the inlet piping to avoid that in case of broken pipe refrigerant side, a lot of water could flow into the system.
- ❑ Using the flooding technology. In this case there are no influence on water flow, but just a flooding of heat exchanging surface by means of a constant back pressure valve and a large liquid receiver.

▪ Air condensed:

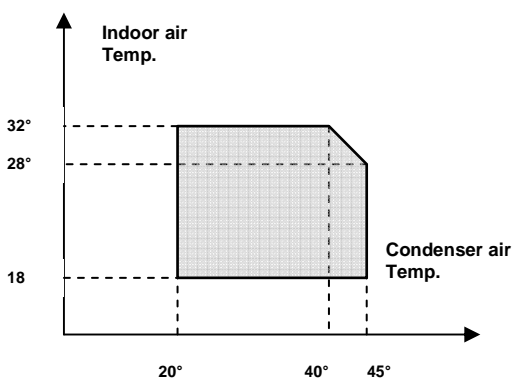

For air temperatures below 20 °C, a condensing control valve is necessary to ensure enough pressure drops across the expansion device. For T below -15° and up to -30°C, a flooding device has to be selected additionally in order to flood the condenser internal surface allowing the right condensing T even in case of strong and cold wind T. This device is shipped as a kit consisting of a back pressure valve, a liquid receiver, a safety valve and mounting instructions: the installation is very simple and has to be done just close to the condensing unit at bottom side.

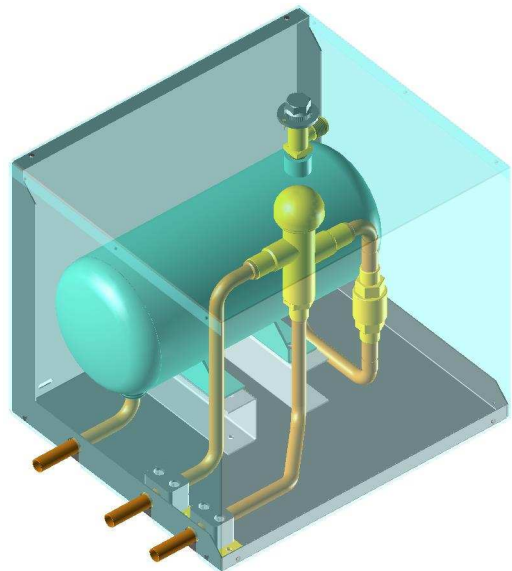

Compressors oil heaters

The "Oil" figure illustrates a specific property [Charles' Law] of gases, which are more soluble in liquids as the pressure increases but less soluble as the temperature increases: if the oil in the sump is held at a constant pressure, an increase in temperature will significantly reduce the amount of refrigerant dissolved in it, thus ensuring that the lubricating function desired is maintained. The problem of inadequate lubrication occurs if the crankcase is not duly heated, above all after seasonal interruptions when, due to the suction effect of the compressor, there is an abrupt drop in pressure inside the sump, which results in considerable evaporation of the refrigerant previously dissolved in the oil. If heating elements were not installed, this phenomenon would cause two problems:

- ❑ Dilution of the oil, hence inadequate lubrication
- ❑ Migration of the oil toward the cooling circuit due to the dragging effect of the refrigerant.



High Technology in Refrigeration Devices

"oil" fig.

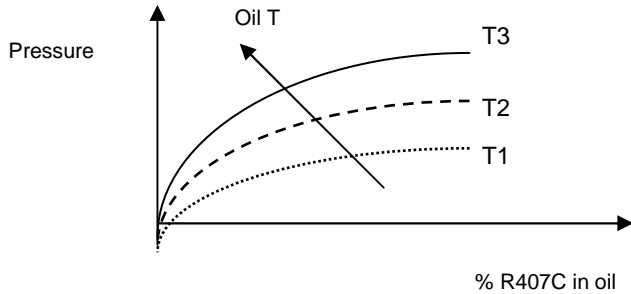

Electrical heaters are necessary when units are put out of order for longer periods and remain at a temperature below 15°C. In case of crankcase heaters, please switch it on at least 12 hours before compressor start up.

Application limits short table

- CW: operating fluid : water or e-glycol mixtures.
- DX: synthetic non dangerous non flammable refrigerant HFC R407C
- PN water side: 16 bar
- Max P refrigerant cycle HP side = 28 bar-r
- Max piping T HP side = 125°C
- Max P refrigerant cycle LP side= 22 bar-r (*)
- Power supply: +/- 10% to the nominal value
- Max storage T = + 50 °C**
- Minimum storage T = - 10 °C
- Max r.h. during storage = 85%

(*) This value influences the maximum storage T for units with a closed refrigerant circuits, like "W" water cooled, "F" free cooling, "Q" Dual cooling" units.

Technical section

Thermodynamics

Refrigerant. The selected refrigerants belong to HFC with an ODP (Ozone Depletion Potential) = 0 according to CEE 2037/00. Standard units are supplied with R407C refrigerant, a mixture of three components R32 (23%), R125(25%) R134a (52%). Due to the presence of more than one component, condensation and evaporation don't happen at constant T as for pure refrigerant: this has a big impact in heat exchanger design in order to combine both temperature profiles, primary and secondary side.

The diagram shows this "temperature glide" and also the beginning condensing T (dew point) and saturated liquid/end of condensation process (bubble point)

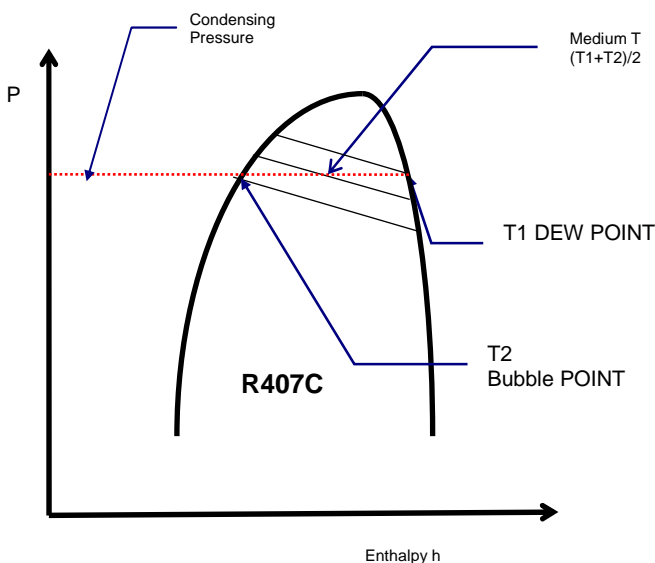

Expansion Valves. The expansion valve is just a mass flow regulator ensuring the right flow checking the superheating at the evaporator outlet. The mass flow depends mainly from the % of opening and from the Delta pressure available across the valve. Mechanical valves have a very little modulating capacity and to ensure the mass flow, a significant Delta P across it has to be maintained. All HiRef products can be supplied with an electronic driven valve (optional) that ensures a big modulation capacity thanks to the big stroke of their shutter: with this solution it is possible to reduce the minimum Delta P across the valve, reducing -in consequence- the condensing T during middle and winter seasons. The minimum allowed condensing T (Dew Point) is 28°C due to scroll compressor mechanical limits.

In this periods the reduction in energy consumption reaches 51 % guaranteeing a shortest payback time for this solution: HiRef R&D department can easily calculate it for specific thermal load and outside T profiles.

The simple schema shows how the valve is managed: a pressure transmitter is reading the evaporating pressure and a T sensor is measuring the Refrigerant T. The mP calculates the superheating and - using special algorithms [part of them patented by HiRef S.p.A. (pat. nr. BO2002A000785 ITA)] - drives the opening/closing of the valve by means of a stepper motor. Only two valves and only one coil cover the entire TREF Range, giving important advantages for spare parts stocking. The same valve is also used for the hot gas bypass function in "Precise" units.

ETV schema

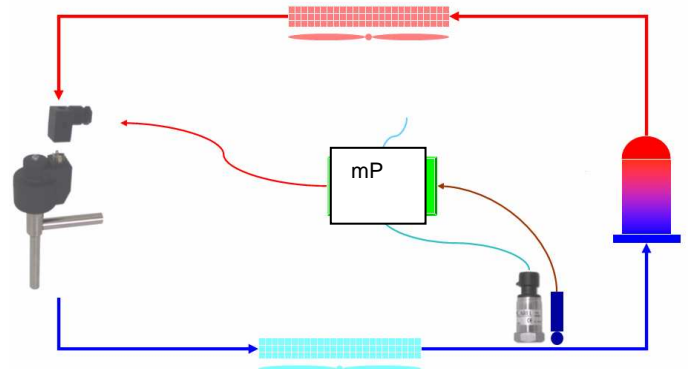

ETV picture





High Technology in Refrigeration Devices

Technical Data for DX Units – Air Cooled

		TADR0201	TADR0251	TADR0281	TADR0311	TADR0401
		TAUR0201	TAUR0251	TAUR0281	TAUR0311	TAUR0401
Air Flow	[m3/h]	6800	6800	7280	7280	12950
Compressor						
Type		Scroll	Scroll	Scroll	Scroll	Scroll
Cooling Capacity @ 24°C 50% R.H. – external air temperature 35°C	[kW]	22,92	23,74	27,68	31,56	42,53
Power consumption	[kW]	5,33	5,65	7,13	7,87	10,71
Nominal Current	[A]	10,14	10,75	13,42	15,14	19,05
FLA	[A]	17	17	20	29	29
LRA	[A]	86	98	130	130	135
POE Oil charge	[l]	3.25	3.25	3.25	4.25	3.3
Finned coil evaporator						
Front Surface	[m2]	0,68	0,68	0,90	0,90	1,31
Geometry		25 x 22	25 x 22	25 x 22	25 x 22	25 x 22
Rows	[-]	5	5	5	5	4
Type of fins	[-]	Idrofilico	Idrofilico	Idrofilico	Idrofilico	Idrofilico
Fin pitch	[mm]	1,8	1,8			1,8
SHR	[-]	0,93	0,91	0,89	0,83	0,90
Indoor fan						
Type		Radiale -EC	Radiale -EC	Radiale -EC	Radiale -EC	Radiale -EC
Power supply	[V-ph-Hz]	400/3/50	400/3/50	400/3/50	400/3/50	400/3/50
Number of fans		1	1	1	1	2
Fans absorbed current	[A]	1,61	1,61	2,01	2,01	1,53
Fans absorbed power	[W]	1007	1007	1252	1252	956
AESP	[Pa]	30	30	30	30	30
AESP (maximum speed)	[Pa]	367,5	367,5	298,4	298,4	382,2
Air Filter						
Filtration		G4	G4	G4	G4	G4
Overall surface	[m2]	1.44	1.44	1.44	2.92	2.92
Fire resistance class		1	1	1	1	1
Electrical heaters						
Total Heating Capacity	[kW]	6,4	6,4	6,4	6,4	9,6
N° of heaters		4	4	4	4	6
Material	[-]	Alluminio	Alluminio	Alluminio	Alluminio	Alluminio
Hot gas Reheating Coil						
Heating capacity	[kW]	16,50	16,70	-	-	37,20
Front Surface	[m2]	0,68	0,68	0,90	0,90	1,31
Hot Water reheating coil						
Heating capacity @ 45/40° water T	[kW]	14,50	14,70	-	-	29,60
Front Surface	[m2]	0,68	0,68	0,90	0,90	1,31
Water flow	[l/h]	2494	2528	-	-	5091
Water side pressure drop	[kPa]	13,00	13,00	-	-	42,00
Water valve pressure drop	[kPa]	14,72	15,13	-	-	10,13
Internal volume	[dm3]	1,6	1,6	-	-	3,2
Humidifier						
Max theoretical capacity	[kg/h]	3	3	3	3	8
Effective capacity	[kg/h]	10,43	10,34	9,93	9,53	10,80
Absorbed power	[kW]	2,25	2,25	2,25	2,25	6
Frame						
H	[mm]	1998	1998	1998	1998	1998
L	[mm]	1010	1010	1270	1270	1760
D	[mm]	795	795	795	795	795
Weight	[kg]	375	385	490	505	595



Technical Data for DX Units – Air Cooled

		TADR0272	TADR0302	TADR0362	TADR0422	TADR0452
		TAUR0272	TAUR0302	TAUR0362	TAUR0422	TAUR0452
Air Flow	[m ³ /h]	12950	12950	12950	12950	12950
Compressor						
Type		Scroll	Scroll	Scroll	Scroll	Scroll
Cooling Capacity @ 24°C 50% R.H. – external air temperature 35°C	[kW]	26.9	31.9	35.9	41.9	44.3
Power consumption	[kW]	6.8	8.5	9.8	11.6	12.2
Nominal Current	[A]	12.2	16.2	17.4	21.4	22.6
FLA (1 compressor)	[A]	10	13	14	17	17
LRA (1 compressor)	[A]	50	66	74	86	98
POE Oil charge	[l]	1.36	1.36	1.65	3.25	3.25
Finned coil evaporator						
Front Surface	[m ²]	1.3	1.3	1.3	1.3	1.3
Geometry		25 x 21,6	25 x 21,6	25 x 21,6	25 x 21,6	25 x 21,6
Rows	[-]	3	3	3	4	4
Type of fins	[-]	Hydrophilic	Hydrophilic	Hydrophilic	Hydrophilic	Hydrophilic
Fin pitch	[mm]	1.8	1.8	1.8	1.8	1.8
SHR	[-]	1.00	0.99	0.98	0.97	0.98
Indoor fan						
Type		Radial-EC	Radial-EC	Radial-EC	Radial-EC	Radial-EC
Power supply	[V-ph-Hz]	400/3/50	400/3/50	400/3/50	400/3/50	400/3/50
Number of fans		2	2	2	2	2
Fans absorbed current	[A]	4.3	4.3	4.3	4.4	4.4
Fans absorbed power	[W]	2500	2500	2500	2595	2600
AESP nominal fan speed	[Pa]	30	30	30	30	30
AESP (maximum speed)	[Pa]	425	425	425	355	355
Air Filter						
Filtration		G4	G4	G4	G4	G4
Overall surface	[m ²]	2.92	2.92	2.92	2.92	2.92
Fire resistance class		1	1	1	1	1
Electrical heaters						
Total Heating Capacity	[kW]	9.6	9.6	9.6	9.6	9.6
N° of heaters		3	3	3	3	3
Material	[-]	Aluminium	Aluminium	Aluminium	Aluminium	Aluminium
Hot gas Reheating Coil						
Heating capacity	[kW]	34.1	33.7	33.7	41.6	42.3
Front Surface	[m ²]	1.05	1.05	1.05	1.05	1.05
Hot Water reheating coil						
Heating capacity @ 45/40°	[kW]	28,7	29,2	30,0	30,0	30,0
Front Surface	[m ²]	1.05	1.05	1.05	1.05	1.05
Water flow	[m ³ /h]	4.936	5.021	5.159	5.159	5.159
Water side pressure drop	[kPa]	39.6	41.0	42.0	42.0	42.0
Water valve pressure drop	[kPa]	7.69	8.42	9.19	10.13	10.61
Internal volume	[dm ³]	2.786	2.786	2.786	2.786	2.786
Humidifier						
Max theoretical capacity	[kg/h]	26.00	21.66	22.41	21.09	23.20
Effective capacity	[kg/h]	8	8	8	8	8
Absorbed power	[kW]	6	6	6	6	6
Frame						
H	[mm]	1998	1998	1998	1998	1998
L	[mm]	1750	1750	1750	1750	1750
D	[mm]	795	795	795	795	795
Weight	[kg]	565	580	590	605	615



High Technology in Refrigeration Devices

Technical Data for DX Units – Air Cooled

		TADR0532	TADR0592	TADR0602	TADR0692	TADR0762
		TAUR0532	TAUR0592	TAUR0602	TAUR0692	TAUR0762
Air Flow	[m ³ /h]	14150	14150	19415	19415	19415
Compressor						
Type		Scroll	Scroll	Scroll	Scroll	Scroll
Cooling Capacity @ 24°C 50% R.H. – external air temperature 35°C	[kW]	53,94	59,08	64,44	71,03	78,59
Power consumption	[kW]	13,94	16,72	16,14	19,53	22,10
Nominal Current	[A]	26,44	31,48	30,76	35,37	39,00
FLA (1 compressor)	[A]	20	29	29	32	32
LRA (1 compressor)	[A]	130	130	130	135	135
POE Oil charge	[l]	3,25	3,25	3,25	3,3	3,25
Finned coil evaporator						
Front Surface	[m ²]	1,5	1,5	1,9	1,9	1,9
Geometry		25 x 22	25 x 22	25 x 22	25 x 22	25 x 22
Rows	[-]	4	4	4	4	4
Type of fins	[-]	Idrofilico	Idrofilico	Idrofilico	Idrofilico	Idrofilico
Fin pitch	[mm]	2,1	2,1	2,1	2,1	2,1
SHR	[-]	0,84	0,80	0,90	0,85	0,81
Indoor fan						
Type		Radiale-EC	Radiale-EC	Radiale-EC	Radiale-EC	Radiale-EC
Power supply	[V-ph-Hz]	400/3/50	400/3/50	400/3/50	400/3/50	400/3/50
Number of fans		3	3	3	3	3
Fans absorbed current	[A]	4,36	4,36	4,93	4,93	4,93
Fans absorbed power	[W]	2718	2718	3074	3074	3074
AESP nominal fan speed	[Pa]	30	30	30	30	30
AESP (maximum speed)	[Pa]	274,2	274,2	363	363	363
Air Filter						
Filtration		G4	G4	G4	G4	G4
Overall surface	[m ²]	4.49	4.49	4.49	4.49	4.49
Fire resistance class		1	1	1	1	1
Electrical heaters						
Total Heating Capacity	[kW]	9,6	12,8	12,8	12,8	12,8
N° of heaters		6	8	8	8	8
Material	[-]	Alluminio	Alluminio	Alluminio	Alluminio	Alluminio
Hot gas Reheating Coil						
Heating capacity	[kW]	-	-	51,30	52,70	53,90
Front Surface	[m ²]	1,5	1,5	1,9	1,9	1,9
Hot Water reheating coil						
Heating capacity @ 45/40°	[kW]	-	-	44,30	46,00	47,60
Front Surface	[m ²]	1,5	1,5	1,9	1,9	1,9
Water flow	[l/h]	-	-	7620	7912	8187
Water side pressure drop	[kPa]	-	-	34,00	35,00	39,00
Water valve pressure drop	[kPa]	-	-	22,68	24,45	26,18
Internal volume	[dm ³]	-	-	5,0	5,0	5,0
Humidifier						
Max theoretical capacity	[kg/h]	8	8	8	8	8
Effective capacity	[kg/h]	10,29	10,02	10,73	10,48	10,14
Absorbed power	[kW]	6	6	6	6	6
Frame						
H	[mm]	1998	1998	1998	1998	1998
L	[mm]	2020	2020	2510	2510	2510
D	[mm]	795	795	795	795	795
Weight	[kg]	730	745	940	958	979



Technical Data DX Units (1 compressor) – Water Cooled

		TWDR0201	TWDR0251	TWDR0281	TWDR0311	TWDR0401
		TWUR0201	TWUR0251	TWUR0281	TWUR0311	TWUR0401
Air Flow	[m ³ /h]	6800	6800	7280	7280	12950
T water 15°C / 30°C						
Cooling Capacity	[kW]	25,26	26,26	31,10	34,37	47,03
Power consumption	[kW]	4,26	4,49	5,47	6,41	8,51
T water 40°C / 45°C (30% e.g.)						
Cooling Capacity	[kW]	21,71	22,74	27,13	30,17	40,95
Power consumption	[kW]	5,84	6,16	7,40	8,66	11,55
Compressor						
Type		Scroll	Scroll	Scroll	Scroll	Scroll
Power supply	[V-ph-Hz]	400/3/50	400/3/50	400/3/50	400/3/50	400/3/50
Nominal Current	[A]	8,91	9,41	11,48	13,46	16,42
FLA	[A]	17	17	20	29	29
LRA	[A]	86	98	130	130	135
POE Oil charge	[l]	3,25	3,25	3,25	4,25	3,3
Finned coil evaporator						
Front Surface	[m ²]	0,7	0,7	0,9	0,9	1,3
Geometry		25 x 22	25 x 22	25 x 22	25 x 22	25 x 22
Rows	[-]	5	5	5	5	4
Type of fins	[-]	Idrofilico	Idrofilico	Idrofilico	Idrofilico	Idrofilico
Fin pitch	[mm]	2,1	2,1	2,1	2,1	2,1
SHR	[-]	0,88	0,87	0,84	0,79	0,86
Indoor fan						
Type		Radiale-EC	Radiale-EC	Radiale-EC	Radiale-EC	Radiale-EC
Number of fans		1	1	1	1	2
Fans absorbed current	[A]	1,61	1,61	2,01	2,01	3,07
Fans absorbed power	[W]	1007	1007	1252	1252	1912
AESP	[Pa]	30	30	30	30	30
AESP (maximum speed)	[Pa]	367,5	367,5	298,4	298,4	382,2
Air Filter						
Filtration		G4	G4	G4	G4	G4
Overall surface	[m ²]	1,44	1,44	1,44	2,92	2,92
Fire resistance class		1	1	1	1	1
Electrical heaters						
Total Heating Capacity	[kW]	6,4	6,4	6,4	6,4	9,6
N° of heaters		4	4	4	4	6
Material	[-]	Alluminio	Alluminio	Alluminio	Alluminio	Alluminio
Hot gas Reheating Coil						
Heating capacity	[kW]	16,50	16,70	17,30	-	37,20
Front Surface	[m ²]	0,7	0,7	0,9	0,9	1,3
Hot Water reheating coil						
Heating capacity @ 45/40° water T	[kW]	14,50	14,70	14,90	-	29,60
Front Surface	[m ²]	0,7	0,7	0,9	0,9	1,3
Water flow	[l/h]	2494	2528	2563	-	5091
Water side pressure drop	[kPa]	13,00	13,00	13,00	-	42,00
Water valve pressure drop	[kPa]	14,72	15,13	15,55	-	10,13
Internal volume	[dm ³]	1,6	1,6	1,6	-	3,2
Humidifier						
Max theoretical capacity	[kg/h]	10,16	9,98	9,54	9,28	10,45
Effective capacity	[kg/h]	9,00	8,83	8,64	8,39	8,78
Absorbed power	[kW]	2,25	2,25	2,25	2,25	6
Frame						
H	[mm]	1998	1998	1998	1998	1998
L	[mm]	1010	1010	1270	1270	1760
D	[mm]	795	795	795	795	795
Weight	[kg]	375	385	490	505	595



Technical Data DX Units (2 compressors) – Water Cooled

		TWDR0272	TWDR0302	TWDR0362	TWDR0422	TWDR0452
		TWUR0272	TWUR0302	TWUR0362	TWUR0422	TWUR0452
Air Flow	[m3/h]	12950	12950	12950	12950	12950
T water 15°C						
Cooling Capacity	[kW]	27.90	34.60	40.60	48.00	50.60
Power consumption	[kW]	5.42	6.96	7.94	9.52	9.98
T water 40°C (30% e.g.)						
Cooling Capacity	[kW]	23.50	28.90	34.00	39.94	42.12
Power consumption	[kW]	7.42	9.26	10.70	12.72	13.34
Compressor						
Type		Scroll	Scroll	Scroll	Scroll	Scroll
Power supply	[V-ph-Hz]	400/3/50	400/3/50	400/3/50	400/3/50	400/3/50
Nominal Current	[A]	12.2	16.2	17.4	21.4	22.6
FLA (1 compressor)	[A]	10	13	14	17	17
LRA (1 compressor)	[A]	50	66	74	86	98
POE Oil charge	[l]	1.36	1.36	1.65	3.25	3.25
Finned coil evaporator						
Front Surface	[m2]	1.3	1.3	1.3	1.3	1.3
Geometry		25 x 21,65	25 x 21,65	25 x 21,65	25 x 21,65	25 x 21,65
Rows	[-]	3	3	3	4	4
Type of fins	[-]	Hydrophilic	Hydrophilic	Hydrophilic	Hydrophilic	Hydrophilic
Fin pitch	[mm]	1.8	1.8	1.8	1.8	1.8
SHR	[-]	1.00	0.99	0.98	0.97	0.98
Indoor fan						
Type		Radial-EC	Radial-EC	Radial-EC	Radial-EC	Radial-EC
Number of fans		2	2	2	2	2
Fans absorbed current	[A]	4.3	4.3	4.3	4.4	4.4
Fans absorbed power	[W]	2500	2500	2500	2595	2600
AESP with std fan	[Pa]	30	30	30	30	30
AESP (maximum speed)	[Pa]	425	425	425	355	355
Air Filter						
Filtration		G4	G4	G4	G4	G4
Overall surface	[m2]	2.92	2.92	2.92	2.92	2.92
Fire resistance class		1	1	1	1	1
Electrical heaters						
Total Heating Capacity	[kW]	9.6	9.6	9.6	9.6	9.6
N° of heaters		3	3	3	3	3
Material	[-]	Aluminium	Aluminium	Aluminium	Aluminium	Aluminium
Hot gas Reheating Coil						
Heating capacity	[kW]	34.1	33.7	33.7	41.6	42.3
Front Surface	[m2]	1.05	1.05	1.05	1.05	1.05
Hot Water reheating coil						
Heating capacity @ 45/40° water T	[kW]	39.6	41	42	42	42
Front Surface	[m2]	1.05	1.05	1.05	1.05	1.05
Water flow	[m3/h]	4.936	5.021	5.159	5.159	5.159
Water side pressure drop	[kPa]	39.6	41.0	42.0	42.0	42.0
Water valve pressure drop	[kPa]	7.69	8.42	9.19	10.13	10.61
Internal volume	[dm3]	2.786	2.786	2.786	2.786	2.786
Humidifier						
Max theoretical capacity	[kg/h]	26.00	21.66	22.41	21.09	23.20
Effective capacity	[kg/h]	8	8	8	8	8
Absorbed power	[kW]	6	6	6	6	6
Frame						
H	[mm]	1998	1998	1998	1998	1998
L	[mm]	1750	1750	1750	1750	1750
D	[mm]	795	795	795	795	795
Weight	[kg]	565	580	590	605	615



Technical Data DX Units (2 compressors) – Water Cooled

		TWDR0532	TWDR0592	TWDR0602	TWDR0692	TWDR0762
		TWUR0532	TWUR0592	TWUR0602	TWUR0692	TWUR0762
Air Flow	[m3/h]	14150	14150	19415	19415	19415
T water 15°C						
Cooling Capacity	[kW]	59,84	66,19	71,23	79,82	87,59
Power consumption	[kW]	10,92	12,76	12,82	14,86	16,88
T water 40°C (30% e.g.)						
Cooling Capacity	[kW]	52,32	58,06	62,10	69,85	77,02
Power consumption	[kW]	14,78	17,28	17,34	20,18	22,98
Compressor						
Type		Scroll	Scroll	Scroll	Scroll	Scroll
Power supply	[V-ph-Hz]	400/3/50	400/3/50	400/3/50	400/3/50	400/3/50
Nominal Current	[A]	12,2	16,2	17,4	21,4	22,6
FLA (1 compressor)	[A]	20	29	29	32	32
LRA (1 compressor)	[A]	130	130	130	135	135
POE Oil charge	[l]	3,25	3,25	3,25	3,3	3,25
Finned coil evaporator						
Front Surface	[m2]	1,5	1,5	1,9	1,9	1,9
Geometry		25 x 22	25 x 22	25 x 22	25 x 22	25 x 22
Rows	[-]	4	4	4	4	4
Type of fins	[-]	Idrofilico	Idrofilico	Idrofilico	Idrofilico	Idrofilico
Fin pitch	[mm]	2,1	2,1	2,1	2,1	2,1
SHR	[-]	0,79	0,76	0,85	0,80	0,76
Indoor fan						
Type		Radiale-EC	Radiale-EC	Radiale-EC	Radiale-EC	Radiale-EC
Number of fans		2	2	2	2	2
Fans absorbed current	[A]	3,98	3,98	4,41	4,41	4,41
Fans absorbed power	[W]	2500	2500	2500	2595	2600
AESP with std fan	[Pa]	30	30	30	30	30
AESP (maximum speed)	[Pa]	274,2	274,2	363	363	363
Air Filter						
Filtration		G4	G4	G4	G4	G4
Overall surface	[m2]	4,49	4,49	4,49	4,49	4,49
Fire resistance class		1	1	1	1	1
Electrical heaters						
Total Heating Capacity	[kW]	9,6	9,6	12,8	12,8	12,8
N° of heaters		6	6	8	8	8
Material	[-]	Alluminio	Alluminio	Alluminio	Alluminio	Alluminio
Hot gas Reheating Coil						
Heating capacity	[kW]	38,60	-	51,30	52,70	53,90
Front Surface	[m2]	1,5	1,5	1,9	1,9	1,9
Hot Water reheating coil						
Heating capacity @ 45/40° water T	[kW]	31,30	-	44,30	46,00	47,60
Front Surface	[m2]	1,5	1,5	1,9	1,9	1,9
Water flow	[m3/h]	5,384	-	7,620	7,912	8,187
Water side pressure drop	[kPa]	45,00	-	34,00	35,00	39,00
Water valve pressure drop	[kPa]	29,00	-	27,00	27,00	27,00
Internal volume	[dm3]	3,2	-	5,0	5,0	5,0
Humidifier						
Max theoretical capacity	[kg/h]	8	8	8	8	8
Effective capacity	[kg/h]	10,02	9,61	10,46	10,12	9,85
Absorbed power	[kW]	6	6	6	6	6
Frame						
H	[mm]	1998	1998	1998	1998	1998
L	[mm]	2020	2020	2510	2510	2510
D	[mm]	795	795	795	795	795
Weight	[kg]	730	745	940	958	979



High Technology in Refrigeration Devices

Technical Data for CW Units (Nominal air flow)

		TCDR0300	TCDR0380	TCDR0400	TCDR0500	TCDR0650	TCDR0750
		TCUR0300	TCUR0380	TCUR0400	TCUR0500	TCUR0650	TCUR0750
Total cooling capacity @ 7/12° Water T. – external air T. 24°50% R.H.	[kW]	32.4	47.6	37.5	51.8	63.8	83.1
Air Flow	[m3/h]	8120	8120	14500	14500	14500	14500
Water flow	[l/s]	1.55	2.27	1.80	2.47	3.05	3.97
Total water pressure drop	[kPa]	46	55.8	37	39	71	73.3
Finned coil evaporator							
Front Surface	[m2]	1.10	1.05	1.90	1.90	1.90	1.85
Geometry		25 x 21,65	25 x 21,65	25 x 21,65	25 x 21,65	25 x 21,65	25 x 21,65
Rows	[-]	3	6	2	3	4	6
Type of fins	[-]	Hydrofilic	Hydrofilic	Hydrofilic	Hydrofilic	Hydrofilic	Hydrofilic
Fin pitch	[mm]	1.8	1.8	1.8	1.8	1.8	1.8
SHR	[-]	0.83	0.77	0.84	0.83	0.82	0.8
Indoor fan							
Type		Radial	Radial	Radial	Radial	Radial	Radial
Power supply	[V-ph-Hz]	400/3/50	400/3/50	400/3/50	400/3/50	400/3/50	400/3/50
Number of fans		1	1	1	2	2	2
Fans absorbed current	[A]	2.5	1.74	4.6	4.8	5.0	3.29
Fans absorbed power	[W]	1482	1000	2756	2816	2942	1800
AESP with std fan	[Pa]	30	30	30	30	30	30
AESP (maximum speed)	[Pa]	380	330	430	405	385	350
Air Filter							
Filtration		G4	G4	G4	G4	G4	G4
Overall surface	[m2]	1.44	1.44	2.92	2.92	2.92	2.92
Fire resistance class		1	1	1	1	1	1
Electrical heaters							
Total Heating Capacity	[kW]	3.2	6.4	6.4	6.4	6.4	9.6
N° of heaters		2	2	3	3	3	3
Material	[-]	Aluminium	Aluminium	Aluminium	Aluminium	Aluminium	Aluminium
Hot Water reheating coil							
Heating capacity @ 45/40° water T	[kW]	14.5	14,7	14.9	25,8	27	29,6
Front Surface	[m2]	0.65	0.65	1.05	1.05	1.05	1.05
Water flow	[m3/h]	2.494	2.528	2.563	4.438	4.644	5.091
Water side pressure drop	[kPa]	13	13	13	33	35	42
Water valve pressure drop	[kPa]	14.72	15.13	15.55	7.69	8.42	10.13
Internal volume	[dm3]	1.44	1.44	2.78	2.78	2.78	2.78
Humidifier							
Max theoretical capacity	[kg/h]	19.6	19.6	41.1	35.4	23.6	23.6
Effective capacity	[kg/h]	8	8	8	8	8	8
Absorbed power	[kW]	6	6	6	6	6	6
Sound pressure level*	[dB(A)]	58	60	60	61	61.5	62
Power Supply	V/Ph/H	230/1/50	230/1/50	230/1/50	230/1/50	230/1/50	230/1/50
Frame							
H	[mm]	1998	1998	1998	1998	1998	1998
L	[mm]	1000	1010	1750	1750	1750	1760
D	[mm]	795	795	795	795	795	795
Weight	[kg]	310	350	370	410	430	475

(*) Obtained at: height 1,5 m., unit frontal side 2 m. in free field, AESP 20 Pa – unit with down flow execution



Technical Data for CW Units (Nominal air flow)

		TCDR0900	TCDR1000	TCDR1200	TCDR1500	TCDR1800	TCDR2100
		TCUR0900	TCUR1000	TCUR1200			
Total cooling capacity @ 7/12° Water T. – external air T. 24° 50% R.H.	[kW]	87.4	101.4	137.9	144,18	177,7	248,48
Air Flow	[l/h]	14376	18352	22974	24799	30564	42739
Water flow	[m3/h]	21400	21400	21400	26200	26200	36120
Total water pressure drop	[kPa]	33,8	62,6	124,0	59,5	103,0	214,3
Finned coil evaporator							
Front Surface	[m2]	2,7	2,7	2,7	5,4	5,4	7,0
Geometry		25 x 22	25 x 22	25 x 22	25 x 22	25 x 22	25 x 22
Rows	[-]	3	4	6	4	6	6
Type of fins	[-]	Idrofilico	Idrofilico	Idrofilico	Idrofilico	Idrofilico	Idrofilico
Fin pitch	[mm]	1,8	1,8	1,8	1,8	1,8	1,8
SHR	[-]	0,82	0,77	0,73	0,76	0,72	0,71
Indoor fan							
Type		Radiale-EC	Radiale-EC	Radiale-EC	Radiale-EC	Radiale-EC	Radiale-EC
Power supply	[V-ph-Hz]	400/3/50	400/3/50	400/3/50	400/3/50	400/3/50	400/3/50
Number of fans		2	2	3		2	
Fans absorbed current	[A]	5,25	5,70	6,11	6,86	7,16	11,29
Fans absorbed power	[kW]	3,276	3,556	3,808	4,279	4,465	7,038
AESP with std fan	[Pa]	30	30	30	30	30	30
AESP (maximum speed)	[Pa]	335,9	311,9	283,9	68,6	54,6	112,2
Air Filter							
Filtration		G4	G4	G4	G4	G4	G4
Overall surface	[m2]	4.49	4.49	4.49		5.75	
Fire resistance class		1	1	1	1	1	1
Electrical heaters							
Total Heating Capacity	[kW]	9,6	9,6	9,6	-	-	-
N° of heaters		4	4	4	-	-	-
Material	[-]	Alluminio	Alluminio	Alluminio	Alluminio	Alluminio	Alluminio
Hot Water reheating coil							
Heating capacity @ 45/40° water T	[kW]	50,20	53,82	53,82	-	-	-
Front Surface	[m2]	2,7	2,7	2,7	5,4	5,4	7,0
Water flow	[l/h]	8634	9257	9257	-	-	-
Water side pressure drop	[kPa]	42,59	48,13	48,13	-	-	-
Water valve pressure drop	[kPa]	11,93	13,71	13,71	-	-	-
Internal volume	[dm3]	4,9	4,9	4,9	-	-	-
Humidifier							
Max theoretical capacity	[kg/h]	54.7	36.4	36.4	-	-	-
Effective capacity	[kg/h]	8	8	8	-	-	-
Absorbed power	[kW]	6	6	6	-	-	-
Sound pressure level†	[dB(A)]	63	63.5	65	-	-	-
Power Supply	V/Ph/H	230/1/50	230/1/50	230/1/50	-	-	-
Frame							
H	[mm]	1998	1998	1998	1998	1998	1998
L	[mm]	2510	2510	2510	2510	2510	3160
D	[mm]	795	795	795	950	950	950
Weight	[kg]	490	510	530	720	753	785

(*) Obtained at: height 1,5 m., unit frontal side 2 m. in free field, AESP 20 Pa – unit with down flow execution



Remote Condenser Technical Data Collection

Remote Condenser – Standard Execution - SHVN

SHVN		38/1	38/1	38/1	46/5	61 V	38/1	46/5
TREF models	Mod.	0201	0251	0281	0311	0401	0272	0302
Power supply	V/Ph/Hz	220/1/50	220/1/50	220/1/50	220/1/50	220/1/50	220/1/50	220/1/50
Air flow	m3/h	8400	8400	8400	14400	14900	8400	14400
Absorbed power	W	720	720	720	1080	1370	720	1080
Absorbed current	A	3.4	3.4	3.4	5.1	6.4	3.4	5.1
Fans	Nr.	4	4	4	6	2	4	6
	mm	350	350	350	350	500	350	350
Sound pressure level in f.f.	dB(A)	46	46	46	48	53	46	48
Dimensions	L mm	1298	1298	1298	1853	2393	1298	1853
[vertical air flow]	D mm	1150	1150	1150	1150	1110	1150	1150
	H mm	863	863	863	863	1270	863	863
Dimensions	L mm	1298	1298	1298	1853	2373	1298	1853
[horizontal air flow]	D mm	380	380	380	380	705	380	380
	H mm	1130	1130	1130	1130	1040	1130	1130
Weight	kg	64	64	64	81	177	64	81

Remote Condenser – Standard Execution - SHVN

SHVN		46/5	61 V	61 V	79 V	79 V	94 V	94 V	106 V
TREF models	Mod.	0362	0422	0452	0532	0592	0602	0692	0762
Power supply	V/Ph/Hz	220/1/50	220/1/50	220/1/50	220/1/50	220/1/50	220/1/50	220/1/50	220/1/50
Air flow	m3/h	14400	14900	14900	23460	23460	22360	22360	31280
Absorbed power	W	1080	1370	1370	2050	2050	2050	2050	2740
Absorbed current	A	5.1	6.4	6.4	9.6	9.6	9.6	9.6	12.8
Fans	Nr.	6	2	2	3	3	3	3	4
	mm	350	500	500	500	500	500	500	500
Sound pressure level in f.f.	dB(A)	48	53	53	54	54	54	54	55
Dimensions	L mm	1853	2393	2393	3393	3393	3393	3393	4393
[vertical air flow]	D mm	1150	1110	1110	1110	1110	1110	1110	1110
	H mm	863	1270	1270	1270	1270	1270	1270	1270
Dimensions	L mm	1853	2373	2373	3373	3373	3373	3373	4373
[horizontal air flow]	D mm	380	705	705	705	705	705	705	705
	H mm	1130	1040	1040	1040	1040	1040	1040	1040
Weight	kg	81	177	177	214	214	239	239	239

- Connection between TREF double circuit and one remote condenser double circuit.



Basic Execution

Model		2 x SHVN 20/4	2 x SHVN 20/4	2 x SHVN 23/2	2 x SHVN 38/1	2 x SHVN 38/1	2 x SHVN 38/1	2 x SHVN 38/1	2 x SHVN 46/5	2 x SHVN 61 V	2 x SHVN 61 V
TREF	mod.	0272	0302	0362	0422	0452	0532	0592	0602	0692	0762
Nr. Of fans x Ø	mm	2 x 350	2 x 350	3 x 350	4 x 350	4 x 350	4 x 350	4 x 350	6 x 350	2 x 500	2 x 500
Air Flow	m ³ /h	4600	4600	7200	8400	8400	8400	8400	14400	14900	14900
Power supply	V/ph/Hz	220/1/50	220/1/50	220/1/50	220/1/50	220/1/50	220/1/50	220/1/50	220/1/50	220/1/50	220/1/50
Absorbed power	W	360	360	540	720	720	720	720	1080	1370	1370
Absorbed current	A	1,7	1,7	2,5	3,4	3,4	3,4	3,4	5,1	6,4	6,4
Sound pressure level in free field	dB(A)	43	43	45	46	46	46	46	48	53	53
Dimensions in case of vertical air flow	L mm	1298	1298	1853	1298	1298	1298	1298	1853	2393	2393
	D mm	600	600	600	1150	1150	1150	1150	1150	1110	1110
	H mm	763	763	763	863	863	863	863	863	1270	1270
Dimensions in case of horizontal air flow	L mm	1298	1298	1853	1298	1298	1298	1298	1853	2373	2373
	D mm	380	380	380	380	380	380	380	380	705	705
	H mm	570	570	570	1130	1130	1130	1130	1130	1040	1040
Weight	kg	37	37	42	64	64	64	64	81	177	177

Low Noise Execution

Model		2 x SHVS 20/2	2 x SHVS 20/2	2 x SHVS 27/1	2 x SHVS 36/0	2 x SHVS 36/0	2 x SHVS 36/0	2 x SHVS 36/0	2 x SHVS 48/1	2 x SHVS 70 V	2 x SHVS 70 V
TREF	mod.	0272	0302	0362	0422	0452	0532	0592	0602	0692	0762
Nr. Of fans x Ø	mm	3 x 350	3 x 350	4 x 350	6 x 350	6 x 350	6 x 350	6 x 350	8 x 350	3 x 630	3 x 630
Air Flow	m ³ /h	3900	3900	5200	9000	9000	9000	9000	12000	18000	18000
Power supply	V/ph/Hz	220/1/50	220/1/50	220/1/50	220/1/50	220/1/50	220/1/50	220/1/50	220/1/50	220/1/50	220/1/50
Absorbed power	W	210	210	280	720	720	720	720	560	1125	1125
Absorbed current	A	1,0	1,0	1.32	3,4	3,4	3,4	3,4	2,6	5,1	5,1
Sound pressure level in free field	dB(A)	35	35	36	38	38	38	38	39	42	42
Dimensions in case of vertical air flow	L mm	1853	1853	1298	1853	1853	1853	1853	2408	3393	3393
	D mm	600	600	1150	1150	1150	1150	1150	1150	1110	1110
	H mm	763	763	863	863	863	863	863	863	1270	1270
Dimensions in case of horizontal air flow	L mm	1853	1853	1298	1853	1853	1853	1853	2408	3373	3373
	D mm	380	380	380	380	380	380	380	380	705	705
	H mm	570	570	1130	1130	1130	1130	1130	1130	1040	1040
Weight	kg	48	48	64	81	81	81	81	104	226	226

- Connection between TREF double circuit and 2 remote condensers single circuit.



Remote Condenser – Low Noise Execution - SHVS

SHVS		36/0	36/0	36/0	48/1	70 V	36/0	48/1
TREF models	Mod.	0201	0251	0281	0311	0401	0272	0302
Power supply	V/Ph/Hz	220/1/50	220/1/50	220/1/50	220/1/50	220/1/50	220/1/50	220/1/50
Air flow	m3/h	9000	9000	9000	12000	18000	9000	12000
Absorbed power	W	420	420	420	560	1125	420	560
Absorbed current	A	2.0	2.0	2.0	2.6	5.1	2.0	2.6
Fans	Nr.	6	6	6	8	3	6	8
	mm	350	350	350	350	630	350	350
Sound pressure level in f.f.	dB(A)	38	38	38	39	42	38	39
Dimensions	L mm	1853	1853	1853	2410	3393	1853	2410
[vertical air flow]	D mm	1150	1150	1150	1150	1110	1150	1150
	H mm	863	863	863	863	1270	863	863
Dimensions	L mm	1853	1853	1853	2410	3373	1853	2410
[horizontal air flow]	D mm	380	380	380	380	705	380	380
	H mm	1130	1130	1130	1130	1040	1130	1130
Weight	kg	81	81	81	104	226	81	104

Remote Condenser – Low Noise Execution - SHVS

SHVS		48/1	70 V	70 V	87 V	87 V	97 V	97 V	111 V
TREF models	Mod.	0362	0422	0452	0532	0592	0602	0692	0762
Power supply	V/Ph/Hz	220/1/50	220/1/50	220/1/50	220/1/50	220/1/50	220/1/50	220/1/50	220/1/50
Air flow	m3/h	12000	18000	18000	24000	24000	22400	22400	30000
Absorbed power	W	560	1125	1125	1500	1500	1500	1500	1875
Absorbed current	A	2.6	5.1	5.1	6.8	6.8	6.8	6.8	8.5
Fans	Nr.	8	3	3	4	4	4	4	5
	mm	350	630	630	630	630	630	630	630
Sound pressure level in f.f.	dB(A)	39	42	42	43	43	43	43	44
Dimensions	L mm	2410	3393	3393	4393	4393	4393	4393	5393
[vertical air flow]	D mm	1150	1110	1110	1110	1110	1110	1110	1110
	H mm	863	1270	1270	1270	1270	1270	1270	1270
Dimensions	L mm	2410	3373	3373	4373	4373	4373	4373	5373
[horizontal air flow]	D mm	380	705	705	705	705	705	705	705
	H mm	1130	1040	1040	1040	1040	1040	1040	1040
Weight	kg	104	226	226	226	226	328	328	355

L= lenght, P= Depth, H= heigh



Dry cooler Technical data

Dry Cooler – Standard Execution - SHLN

SHLN		58 D	73 C	73 C	83 C	110 D	73 C	83 C
TREF models	Mod.	0201	0251	0281	0311	0401	0272	0302
Power supply	V/Ph/Hz	220/1/50	220/1/50	220/1/50	220/1/50	220/1/50	220/1/50	220/1/50
Air flow	m3/h	12880	19050	19050	19320	25760	19050	19320
Absorbed power	W	1482	2230	2230	2230	2970	2230	2230
Absorbed current	A	6.6	9.9	9.9	9.9	13.2	9.9	9.9
Fans	Nr.	2	3	3	3	4	3	3
	mm	500	500	500	500	500	500	500
Sound pressure level in f.f.	dB(A)	50	51	51	51	53	51	51
Dimensions	L mm	1895	2705	2705	2705	1895	2705	2705
[vertical air flow]	D mm	810	810	810	810	1625	810	810
	H mm	1070	1070	1070	1070	1070	1070	1070
Dimensions	L mm	1895	2705	2705	2705	1895	2705	2705
[horizontal air flow]	D mm	470	470	470	470	470	470	470
	H mm	830	830	830	830	1645	830	830
Weight	kg	102	132	132	144	190	132	144

Dry Cooler – Standard Execution - SHLN

SHLN		98 C	110 D	118 F	147 C	147 C	182 C	182 C	208 B
TREF models	Mod.	0362	0422	0452	0532	0592	0602	0692	0762
Power supply	V/Ph/Hz	220/1/50	220/1/50	220/1/50	220/1/50	220/1/50	220/1/50	220/1/50	220/1/50
Air flow	m3/h	25760	25760	31200	38100	38100	46800	46800	66400
Absorbed power	W	2970	2970	2480	4450	4450	3720	3720	4960
Absorbed current	A	13.2	13.2	11.2	19.8	19.8	16.8	16.8	22.4
Fans	Nr.	4	4	4	6	6	6	6	8
	mm	500	500	630	500	500	630	630	630
Sound pressure level in f.f.	dB(A)	53	53	50	54	54	52	52	53
Dimensions	L mm	1895	1895	4676	2705	2705	3393	3393	4393
[vertical air flow]	D mm	1625	1625	1110	1625	1625	2120	2120	2120
	H mm	1070	1070	1270	1070	1070	1270	1270	1270
Dimensions	L mm	1895	1895	4676	2705	2705	3393	3393	4393
[horizontal air flow]	D mm	470	470	710	470	470	990	990	990
	H mm	1645	1645	1040	830	830	2120	2120	2120
Weight	kg	174	190	328	288	288	522	449	522

Selection related to 30°C Air Temperature and 45/40°C 30%e.g. water conditions.
Max Air T = 40°C



Dry Cooler – Low Noise Execution - SHLS

SHLS		59 C	72 C	72 C	87 D	114 D	72 C	87 D
TREF models	Mod.	0201	0251	0281	0311	0401	0272	0302
Power supply	V/Ph/Hz	220/1/50	220/1/50	220/1/50	220/1/50	220/1/50	220/1/50	220/1/50
Air flow	m3/h	12400	16800	16800	24000	24820	16800	24000
Absorbed power	W	816	1125	1125	1500	1640	1125	1500
Absorbed current	A	3.6	5.1	5.1	6.8	7.3	5.1	6.8
Fans	Nr.	3	3	3	4	6	3	4
	mm	500	630	630	630	500	630	630
Sound pressure level in f.f.	dB(A)	42	42	42	43	44	42	43
Dimensions	L mm	2710	3393	3393	4393	2710	3393	4393
[vertical air flow]	D mm	810	1110	1110	1110	1625	1110	1110
	H mm	1070	1270	1270	1270	1070	1270	1270
Dimensions	L mm	2710	3393	3393	4393	2710	3393	4393
[horizontal air flow]	D mm	470	990	990	990	470	990	990
	H mm	830	1040	1040	1040	1645	1040	1040
Weight	kg	132	251	251	298	250	251	298

Dry Cooler – Low Noise Execution - SHLS

SHLS		97 C	114 D	117 B	141 C	141 C	173 B	188 B	213 B
TREF models	Mod.	0362	0422	0452	0532	0592	0602	0692	0762
Power supply	V/Ph/Hz	220/1/50	220/1/50	220/1/50	220/1/50	220/1/50	220/1/50	220/1/50	220/1/50
Air flow	m3/h	22400	24820	28000	33600	33600	48000	44800	60000
Absorbed power	W	1500	1640	1875	2250	2250	3000	3000	3750
Absorbed current	A	6.8	7.3	8.5	10.2	10.2	13.6	13.6	17.0
Fans	Nr.	4	6	5	6	6	8	8	10
	mm	630	500	630	630	630	630	630	630
Sound pressure level in f.f.	dB(A)	43	44	44	45	45	46	46	46
Dimensions	L mm	4393	2710	5393	3393	3393	4393	4393	5393
[vertical air flow]	D mm	1110	1625	1110	2120	2120	2120	2120	2120
	H mm	1270	1070	1270	1270	1270	1270	1270	1270
Dimensions	L mm	4393	2710	5393	3393	3393	4393	4393	5393
[horizontal air flow]	D mm	990	470	990	990	990	990	990	990
	H mm	1040	1645	1040	2120	2120	2120	2120	2120
Weight	kg	328	250	390	450	450	522	582	629

Selection related to 30°C Air Temperature and 45/40°C 30%e.g. water conditions.
Max Air T = 40°C



Refrigerant Pipes

On site piping has to be installed by professional workers using only CUB quality copper pipes. Take care in use of nitrogen during all brazing operations in order to avoid humidity and dirty in pipes.

Refrigerant		R407C	R407C	R407C	R407C	R407C	R407C	R407C	R407C	R407C	R407C	R407C
Cooling Capacity	[kW]	4-5	6-7	8-9	10-11.5	11.5-13	14-16	17-18	19-24	25-29	30-34	35-40
HP Gas line 0-10m	[mm]	12	12	12	16	16	16	16	22	22	22	28
Liquid line 0-10m	[mm]	10	10	10	12	12	12	12	16	16	16	18
HP Gas line 11-20m	[mm]	12	12	16	16	16	18	18	22	22	28	28
Liquid line 11-20m	[mm]]	10	10	12	12	12	12	12	16	16	18	18

Standard Copper pipes

Diameter [mm]	Thickness [mm]	Minimum bending radius [mm]	System design pressure PS [bar]	PED Category	Max Copper σ_s [N/mm ²]	Real copper σ [N/mm ²]	Safety ratio
10	1	36	28	A3 P3	227	11.2	20.3
12	1	36	28	A3 P3	227	14	16.2
16	1	46	28	A3 P3	227	19.6	11.6
18	1	56	28	A3 P3	227	21	10.8
22	1,5	67	28	A3 P3	227	17.3	13.1
28	1,5	96	28	A3 P3	227	23.3	9.8
35	1.5	70	28	A3P3	227	29.8	7.6
42	1.5	84	28	A3P3	227	36.4	6.2
54	2.0	108	28	A3P3	227	35	6.4



High Technology in Refrigeration Devices



High Technology in Refrigeration Devices



High Technology in Refrigeration Devices

High Technology in Refrigeration Devices

HiRef S.p.A. Viale Spagna, 31/33 - 35020 Tribano (PD) – Italy

Tel. +39 049 9588511 - Fax +39 049 9588522

e-mail: info@hiref.it - Web: <http://www.hiref.it>



Tutti i diritti riservati.

Nessuna parte di questa pubblicazione può essere riprodotta senza preventivo permesso scritto da HiRef. HiRef S.p.A. si riserva il diritto di modificare le specifiche ed altre informazioni contenute in questa pubblicazione senza dover fornire notizia preventiva. "In nessun caso HiRef sarà responsabile per ogni danno a cose e/o persone, che sia provocato in modo diretto o indiretto a causa dalle informazioni contenute in questa pubblicazione."